

# SAMPLE

## Japan University Examination Physics

( 60 min )

**Do not open the examination booklet until the starting signal for the exam is given.**

**Please read the following instructions carefully.**

**Please fill in the examinee no. and name below.**

### | | |--------------| | Instructions | |--------------|

1. The booklet contains 19 pages.
2. The answer sheet is one piece of one sided paper.
3. In the case that you notice there are parts in the booklet where the print is not clear or there are missing pages or misplaced pages, or the answer sheet is soiled, raise your hand to report to the invigilator.
4. There are 4 questions to be answered.
5. Fill the examinee no. and name in the answer sheet.
6. Use black pencil to write answers in the designated section in the answer sheet.
7. Memos and calculations can be written on the examination booklet.
8. When the signal to end the exam is given, check again to see that the examinee no. and name is filled in and submit the answer sheet and the examination booklet according to the invigilator's instructions.

Examinee's No.	Name



# Physics

Part 1 Please answer the following questions (Question 1 ~ 5) .

Question 1 As shown in Fig.1, the small ball begins to fall at 0 of initial velocity. During the small ball reaches the floor, for the relationship between the kinetic energy  $K$  and the height  $h$  from the floor, which graph is the right answer? Please choose one from the following ①~④. Note: It is assumed the resistance of air is negligible.

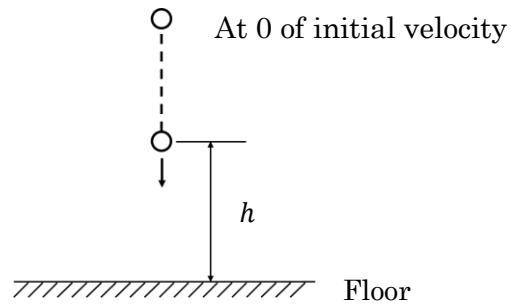
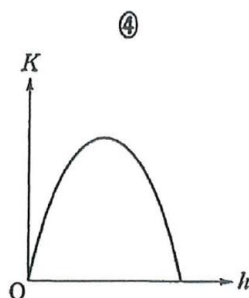
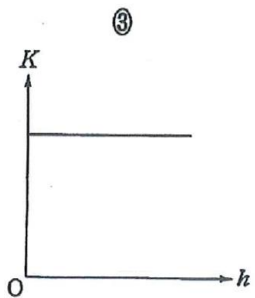
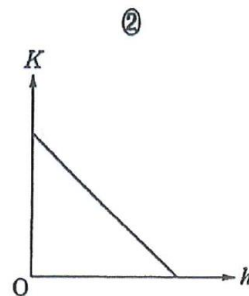
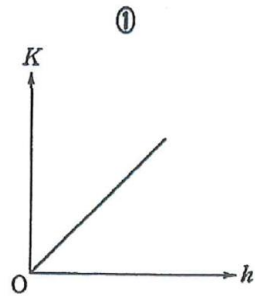

Fig.1



Question 2 As shown in Fig.2, on the  $x$  - axis, a pulse wave with the trapezoidal waveform (isolated wave) is proceeding to the fixed end P at speed  $1 \text{ m / s}$ . For the waveform (the synthetic wave of the incident wave and the reflected wave) after 4 seconds from the time of Fig.2, which figure is the right answer? Please choose one from the following ①~⑤. Note: The distance of the scale for  $x$  - axis is  $1 \text{ m}$ , and there is no attenuation of the waves due to reflection.

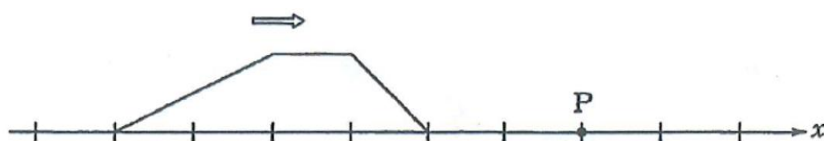
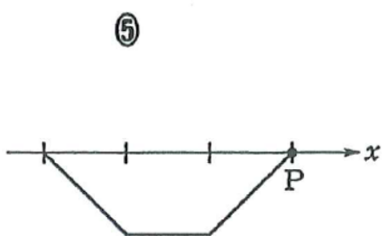
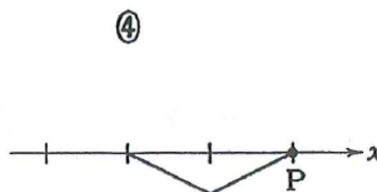
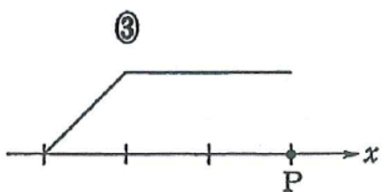
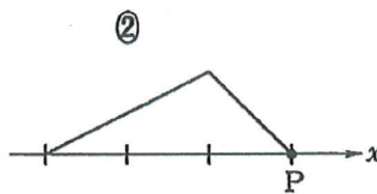
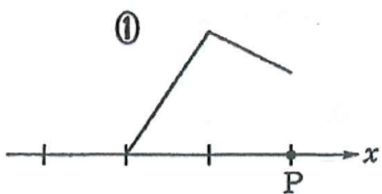

Fig. 2



Question 3 As shown in Fig. 3, the metal wires **a** and **b** was connected in line, and was connected with the battery for certain voltage battery, then measured the current of the circuit. In this circuit, except the metal wires **a** and **b**, other resistance was negligible. At the beginning, both metal wires had same resistance at  $0^{\circ}\text{C}$  temperature, and the current of the circuit was  $I_0$ . When kept the temperature of the metal wires **a** at  $0^{\circ}\text{C}$  and raised the temperature of the metal wires **b**, the current of the circuit reduced to  $I_1$ .

For the reason of current reduction, please choose a right answer from the following ① ~ ④.

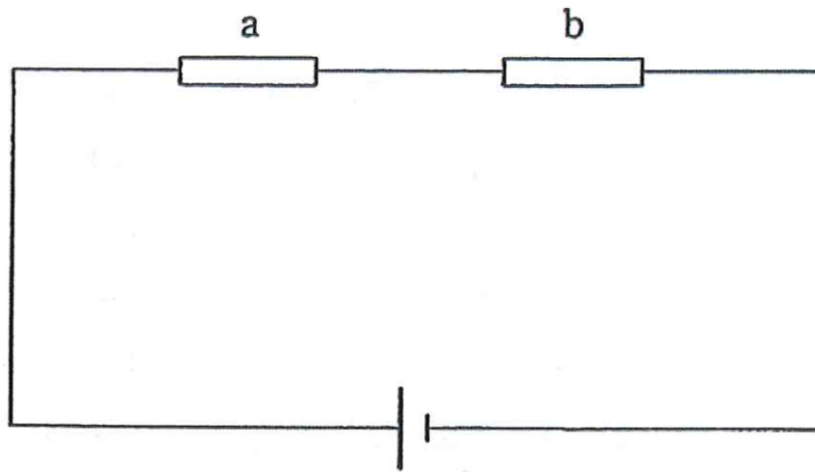

Fig. 3

- ① The vibration of atoms in the metal wire **b** became active, and so the progress of the free electrons was prevented.
- ② The vibration of atoms in the metal wire **b** became active, and so the progress of the free electrons was promoted.
- ③ The vibration of atoms in the metal wire **b** became slow, and so the progress of the free electrons was prevented.
- ④ The vibration of atoms in the metal wire **b** became slow, and so the progress of the free electrons was promoted.

Question 4 For the following article, please choose a right pair which the words fill in the blank  ~  from ①~④ below.

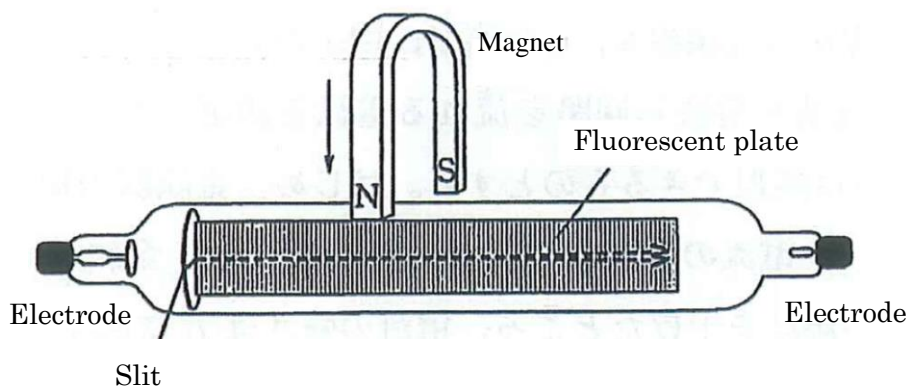

Fig. 4

Make the glass tube in the vacuum, when apply a high voltage on both electrodes, then  release from the  pole. B. Is d. The flow of the  called  ray.

In order to see the  ray easily, put the slit and the fluorescent plate in front of the  pole , as shown in Fig.4, when the  ray was being released, N pole of the magnet moved to the front of the glass tube and S pole moved to the opposite side (The direction of the magnetic force (magnetic field) is from N pole to S pole), as shown the direction of the arrow, then observed the  ray bent to  direction. This could explain that the current was affected by the force from the magnetic field.

	A	B	C
①	cathode	electron	up
②	cathode	electron	down
③	anode	proton	up
④	anode	proton	down

Question 5 As shown in Fig. 5, the cylinders and pistons of container A and B were made by heat insulating material with a heater on the bottom separately, and they had the same shape. Put the equal quantity gas with the same temperature, pressure and volume into container A and B by confined respectively. Placed container A and B in the atmosphere condition, and the piston of A was fixed, the piston of B could move freely. Next step used the heaters to heat the gas slowly and respectively.

With the state change of the gas in container A and B, for graph of the relationship between pressure and volume of the gas respectively, please choose a right pair from the following ① ~ ⑥.

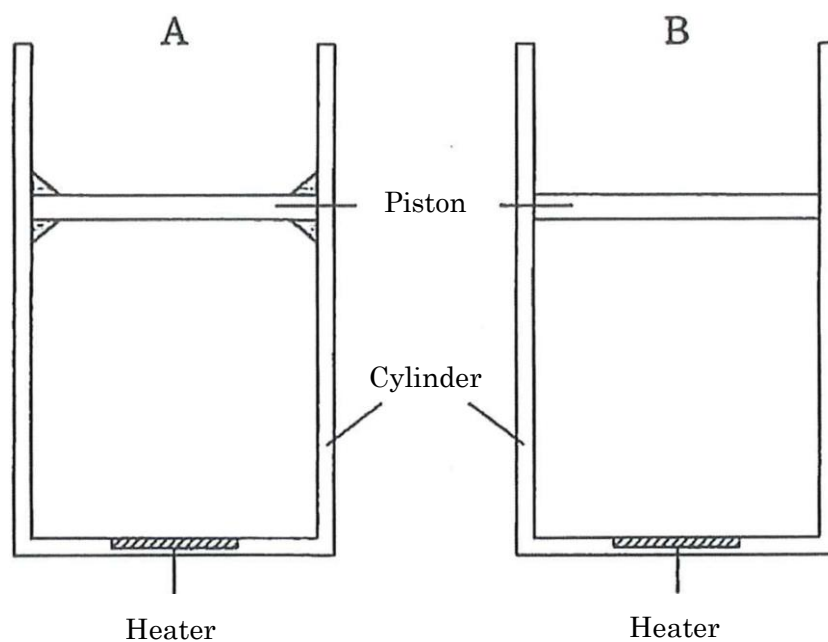
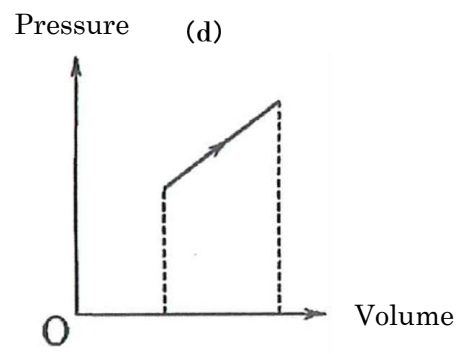
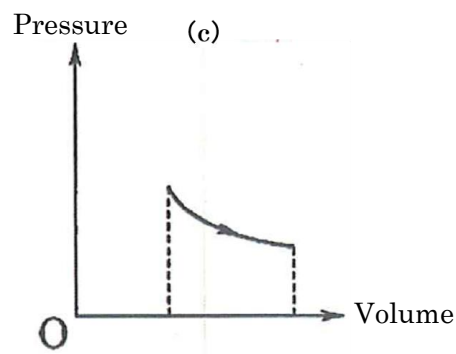
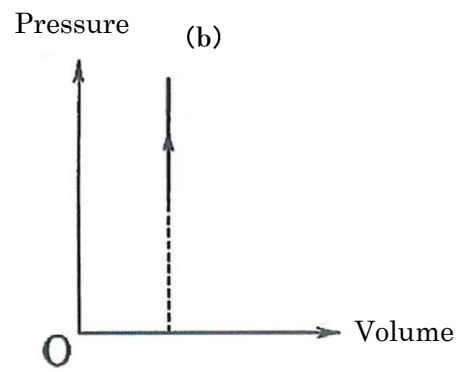
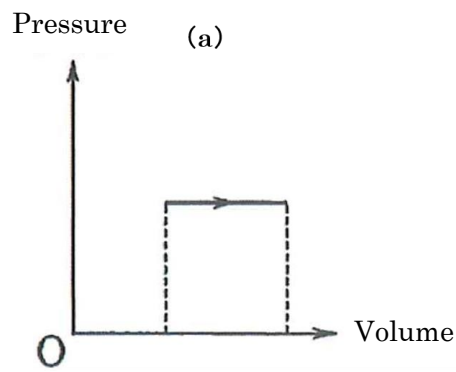

Fig. 5



	A	B
①	(a)	(b)
②	(a)	(c)
③	(a)	(d)
④	(b)	(a)
⑤	(b)	(c)
⑥	(b)	(d)



Part 2 . Read the following article, and answer the questions (Question 1 ~ 6 )  
below.

As shown in Fig.1, taking the original point  $O$  from the smooth slope, and taking the upward direction along the slope as  $x$ -axis. When the time was  $t = 0$  , small object  $a$  began to slide along the positive direction of  $x$  -axis at initial velocity  $v_0$ , and  $a$  moved at certain acceleration  $a$  ,then became stationary momentarily at point A where the distance was  $\ell$  from the original point  $O$ , next slid down to the original point  $O$  again. During the time, the relationship between the distance  $x$  of small object  $a$  and the time as shown in Fig.2, and the relationship between the speed  $v$  and time  $t$  as shown in Fig.3. Note: The positive direction of speed is same with  $x$  -axis, and the scales of time axis are not equal for Fig.2 and Fig.3.

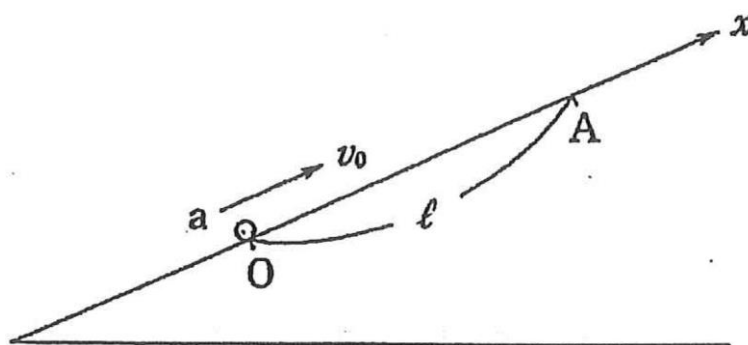

Fig. 1

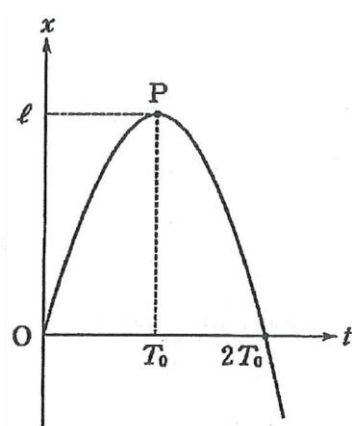

Fig. 2

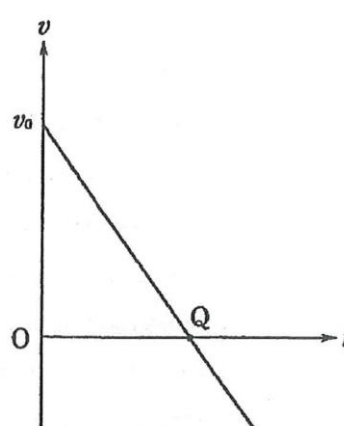

Fig. 3

Question 1 For the following article, please choose a right pair which the words fill in the blank  ·  from ①~④ below.

Since the time at point P or so, the direction of  for small object *a* began to change , then time at the point Q in Fig. 3 was  .

	X	Y
①	speed	$T_0$
②	speed	$2T_0$
③	acceleration	$T_0$
④	acceleration	$2T_0$

Question 2 In Fig.2, what is the time  $T_0$ ? Please choose the right answer from the following ①~⑥.

- ①  $\frac{v_0}{4a}$                       ②  $\frac{v_0}{2a}$                       ③  $\frac{v_0}{a}$   
 ④  $\frac{\sqrt{2}v_0}{a}$                       ⑤  $\frac{2v_0}{a}$                       ⑥  $\frac{4v_0}{a}$

Question 3 What is the distance  $\ell$ ? Please choose the right answer from the following ①~④.

- ①  $\frac{v_0^2}{4a}$                       ②  $\frac{v_0^2}{2a}$                       ③  $\frac{v_0^2}{a}$                       ④  $\frac{2v_0^2}{a}$

Question 4 If the initial velocity of small object  $a$  become 2 times than before, then what is right relationship between the distance  $x$  and the time  $t$  while small object  $a$  backs to the original point O? Please choose the right answer from the following ①~④.

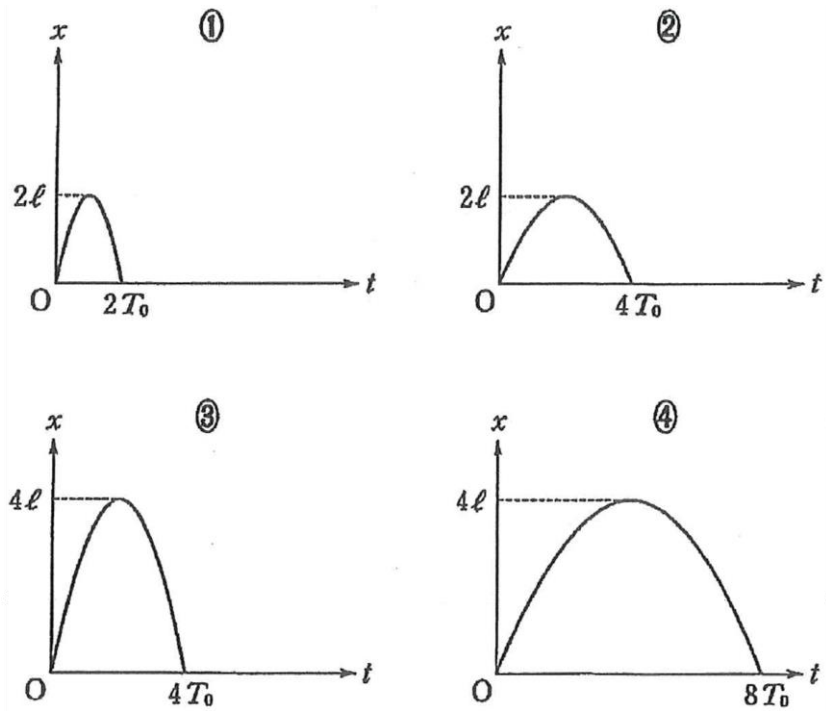

Question 5 As shown in Fig. 4, at the time  $t = 0$ , small object **a** began to slide along the positive direction of  $x$ -axis at initial velocity  $v_0$  from the original point **O** on the same slope as same with Fig. 1, at the moment, small object **b** began to slide along the positive direction of  $x$ -axis at initial velocity  $\frac{1}{2}v_0$  from the distance  $x = \frac{1}{2}\ell$ . Then what was the right graph for the relationship between the relative velocity  $u$  and the time  $t$  from **b** to **a**? Please choose right one from the following ①~④. Note: The graph of collided by **a** and **b** do not be shown in the following.

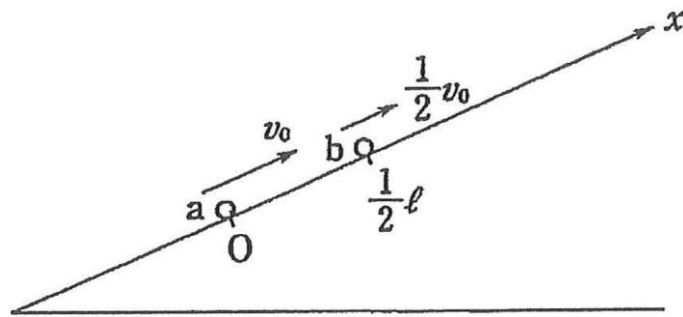
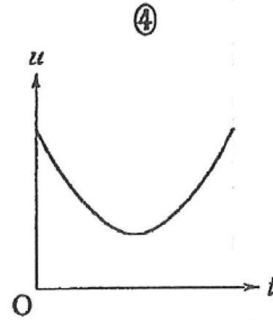
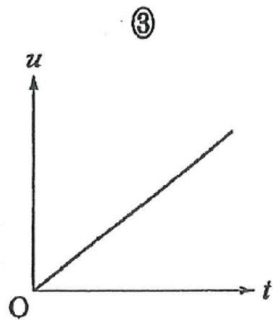
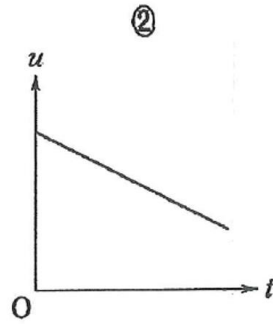
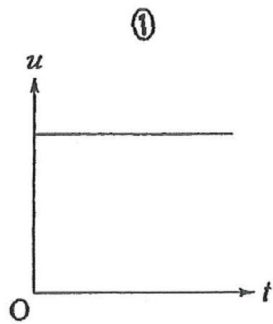

Fig. 4



Question 6 What is the time for **a** and **b** to collide? Please choose the right answer from the following ①~⑤.

①  $\frac{\ell}{4v_0}$

②  $\frac{\ell}{2v_0}$

③  $\frac{\ell}{v_0}$

④  $\frac{2\ell}{v_0}$

⑤  $\frac{4\ell}{v_0}$

Part 3 Please read the following articles (A~C) , and answer the questions (Question 1 ~ 6 ) below.

A As shown in Fig.1, put 150g oil into the container which was wrapped with heat insulating material, and the container was heated by a heater (a resistor with  $20\ \Omega$ ) which was installed in the bottom. Note: The heat capacity of the container was  $85\text{J} / \text{K}$ , and the oil has not been evaporated, in addition the heat capacity of the heater and other resistance except the heater is assumed to be negligible.

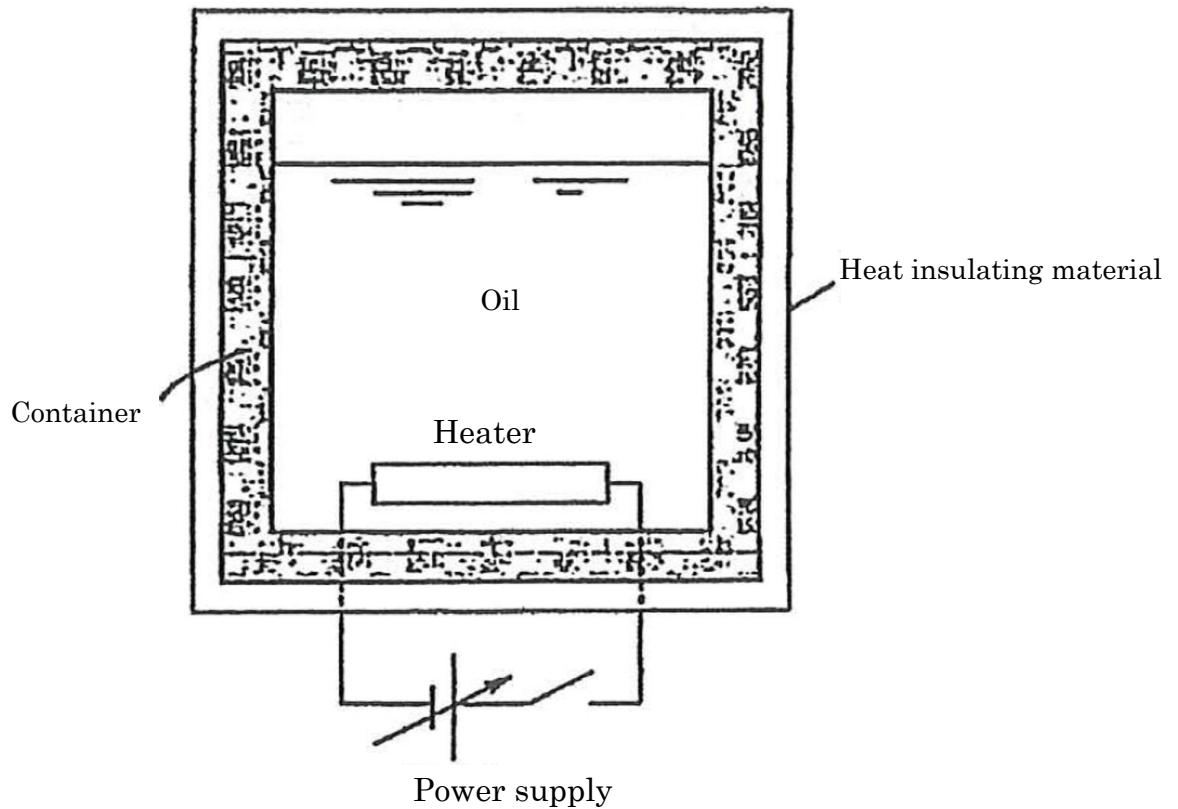

Fig. 1

Question 1 If heat the container by a heater at  $80\text{W}$ , then how much voltage is for the power supply ?

Question 2 The specific heat of the oil in the container is set to  $c$  [ $\text{J} / (\text{g} \cdot \text{K})$ ]. In order to make the temperature in the container is raised  $1^\circ\text{C}$ , then how much amount of heat should be given from the heater?

Note: All the heat generated by the heater is assumed to be given to oil and container.

Question 3 When the heater was electrified one minute at  $80\text{W}$ , the temperature in the container raised for  $12^\circ\text{C}$ . Then how much  $\text{J}/(\text{g} \cdot \text{K})$  is for the specific heat  $c$  of the oil in the container? Please give the answer.

B By connecting a single resistor to a current meter, it is possible to make a current meter for measuring the larger current. First, prepare a current meter X with an internal resistance for  $1.2\ \Omega$  and the maximum scale for  $4\text{A}$ . As shown in Fig. 2, make a device Y by connecting a resistance  $r$  for  $0.3\ \Omega$  with X in parallel. When Y has a current for  $20\text{A}$ , then the X of Y has a current for  $4\text{A}$ , and the  $r$  has a current for  A. Therefore, if rewrite the maximum scale of the X from  $4\text{A}$  to  $20\text{A}$ , then the instrument Y will be a current meter with the maximum scale for  $20\text{A}$ .

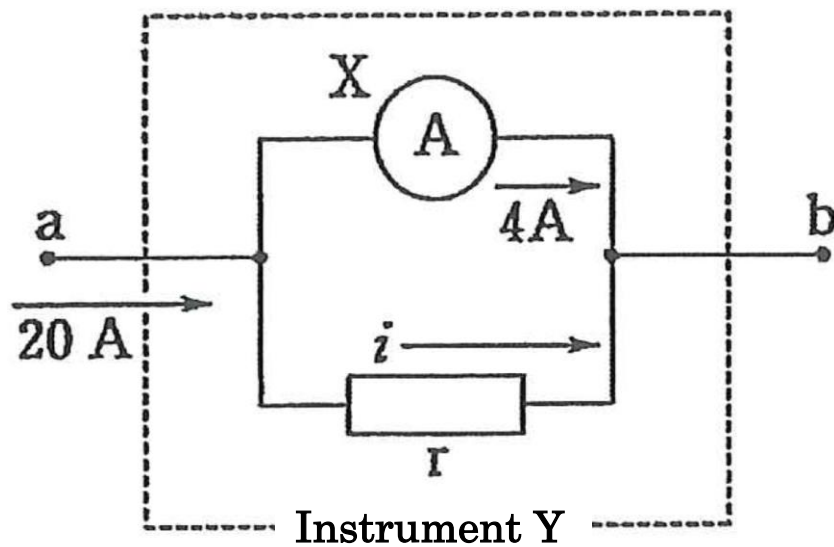

Fig. 2

Question 4 For the article, what is the right number that fill in blank  ?

Question 5 How many Ohms ( $\Omega$ ) are for the resistance (combined resistance between **a** and **b**) of the instrument Y?



C Further, by connecting a single resistor to the aforementioned current meter X, it is also possible to make a voltage meter. As shown in Fig.3, make a device Z by connecting a resistance R with X in line. When the resistance of R is   $\Omega$ , and applying a voltage of 40V between the terminals *c* and *d* of Z, then X has the largest current for 4A. At the moment, if rewrite the maximum scale of the X from 4A to 40V, then the instrument Z will be a voltage meter with the maximum scale for 40V.

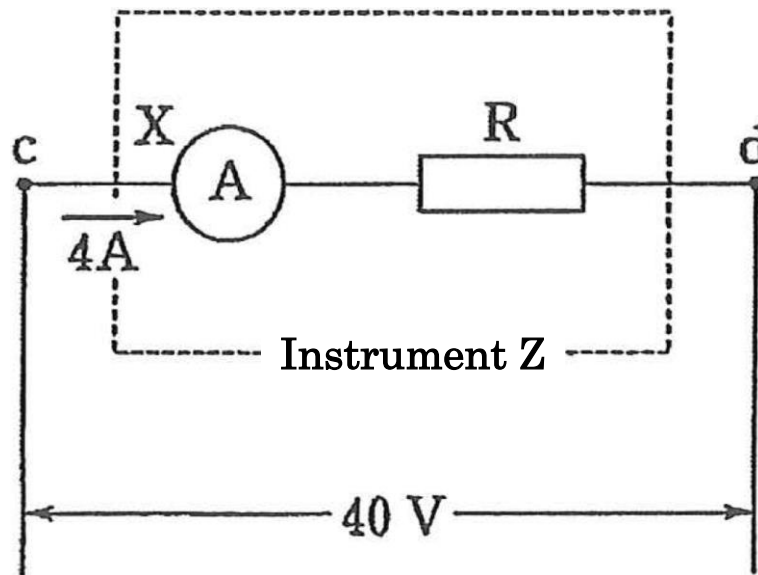

Fig. 3

Question 6 For the article, what is the right number that fill in blank  ?

Part 4 Please read the following articles (A · B) , and answer the questions (Question 1 ~5) below.

A As shown in Fig.1, the string is attached at one end of the branches of the electromagnetic tuning fork with the frequency  $f$  , and also it is stretched horizontally by subjected to the smooth fixed pulley. The other end of the string has been suspended with a container which weighs is negligible, and this container can be put in the required numbers of equal weight farmers. At first, put two farmers in the container, when operating the electromagnetic tuning fork, the string has occurred standing waves which have two bellies as shown in Fig.1. Note: The length of the vibrating portion of the strings is  $L$ , and the speed of transverse waves propagating to the square root with the tension of the string.

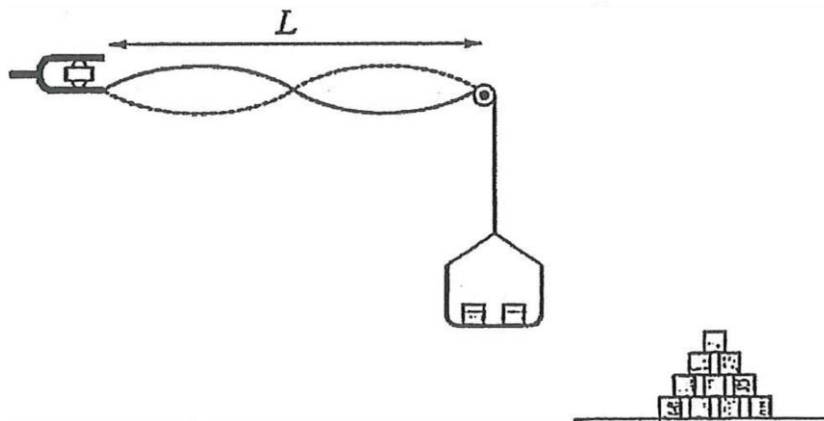

Fig. 1

Question 1 When the standing waves with two bellies have occurred, what is the traveling speed of the transverse wave on the string?

Question 2 While operating the electromagnetic tuning fork, and observed the vibrations of the strings to increase the farmer one by one. Then when the next standing wave appeared, the number of belly became one. In this case, how many farmers are put in the container?

B As shown in Fig.2, when the monochromatic parallel light with wavelength  $\lambda$  incident the diffraction grating vertically, then a number of bright lines were observed on a screen that was placed in front. The bright lines distributed symmetrically around the point O which was the incident direction of the light beam, and the bright lines that passed through the point O called zero- grade, then by order according to the distance from the point O, the bright lines called 1- grade, 2- grade ... and so on. Fig. 3 is an enlarged view of a diffraction grating, since the portion between the groove and the groove carved at equal interval  $d$  on the surface serves as a slits, so in the following it will be referred as slits. In Fig.3, the interval of the wavefront of the light that spreads diffracted from the slits is one wavelength.

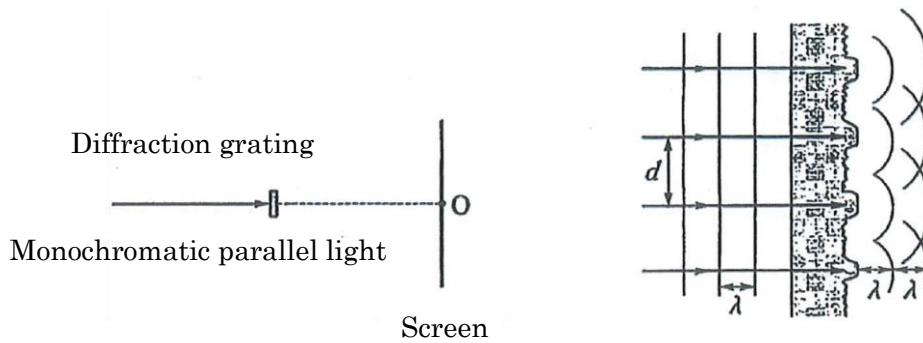
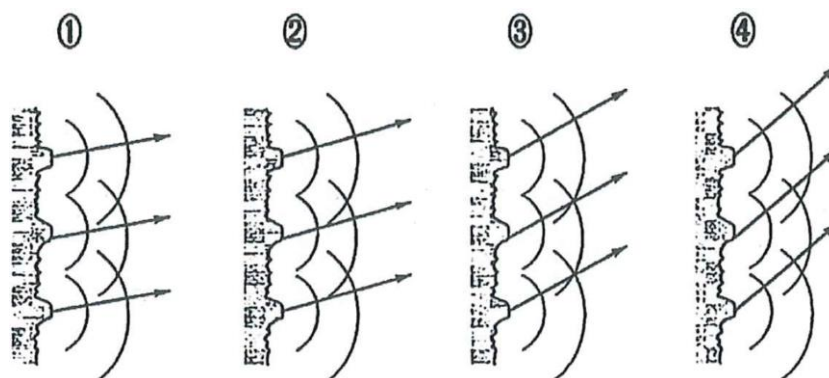

Fig. 2

Fig. 3

Question 3 The reason that bright line occurs is because the light interference when the light is diffracted through the slits. For the direction of 1- grade, which one is the right diagram? Please choose one from the following ①~④. Note: The interval of the wavefront of the light is same as one wavelength with Fig.3.



Question 4 The wavelength of the parallel light is  $\lambda = 6.3 \times 10^{-7}m$ . In Tab. 1, the value of the measured angle that caused between the direction of the bright line and the incident direction of the light and trigonometric function of angle are shown, including form the zero- grade to 2- grade. What is the interval  $d$  of the groove each other? Please choose the right one form the following① ~ ⑥ .

Grade	0	1	2
$\theta$ [Degree]	0.0	9.5	19.5
$\cos \theta$	1.00	0.986	0.943
$\sin \theta$	0.00	0.165	0.334
$\tan \theta$	0.00	0.167	0.354

Tab. 1

- ①  $2.2 \times 10^{-7}$                       ②  $3.3 \times 10^{-7}$                       ③  $3.8 \times 10^{-7}$   
 ④  $2.2 \times 10^{-6}$                       ⑤  $3.3 \times 10^{-6}$                       ⑥  $3.8 \times 10^{-6}$

Question 5 Which one is the phenomenon that is not related to interference and diffraction? Please choose the right answer from the following ① ~ ⑤.

- ① When stood under the thick and high wall, but still heard the sound form the other side.  
 ② The recording surface of the CD (compact disc) is looked colored by a variety of colors.  
 ③ Waves penetrated into the harbor that surrounded by the breakwater.  
 ④ Rainbow appeared in the sky after the rain.  
 ⑤ When make a soap bubble, the surface looked colored.

